

Monitor Arms Specification



CONTENTS:

Dynamo Dynamic Monitor Arm	2
Flo Monitor Arm	3
Flo Plus Monitor Arm	4
Flo X Monitor Arm	5
Lima Monitor Arm	6
M2.1 Monitor Arm	7
M8.1 Monitor Arm	8
Ollin Monitor Arm	9

Dynamo Dynamic Monitor Arm

Features:

Dynamo is a dynamic monitor arm intuitively designed to deliver seamless handling across installation, mounting and adjusting. Dynamo effortlessly rotates, pivots and extends, enabling tool-less and absolute adjustment to minimise eye and posture strain. Dynamo comes with 180 degree locking mechanism for lateral arm movement and load rating of 2-8kg for flat screens only.

Options:

- Vesa mount laptop tray

Design: CMS Electracom

Warranty: 5 years

Finishes:

Powder coat:



White



Black

Dimensions:

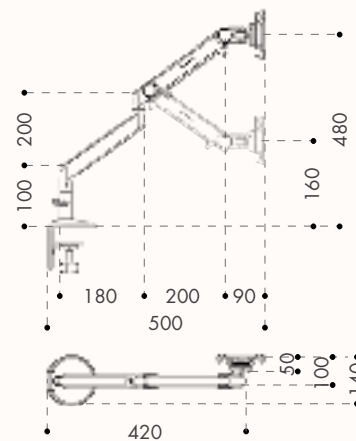

Flo Monitor Arm

Features:

Flo Monitor Arm primary purpose is to support a single monitor screen but due to its ingenious design, it can be easily customised to support a laptop. Achieved by the use of geometric Flo Spring Technology, its unique design is protected by four international patents. Its design provides unrivaled degree of flexibility for touch screens.

The monitor arm also supports 3kg to 9kg load range, ideal for mounting lighter technology such as monitors and laptops. Available with a Flo Split Clamp and 3 point cable management guide to prevent clutter of cables. The Vesa Plate attached to the arm allows users to rotate their screen portrait to landscape. It also consists of a weight gauge indicator that reduces its installation time and provides consistent performance.

Design: CBS DESIGN for COLEBROOK BOSSON SAUNDERS

Warranty: 12 years

Awards: Reddot Design Award Winner 2011

Finishes:

Power coat:



White



Black



Silver

Dimensions:

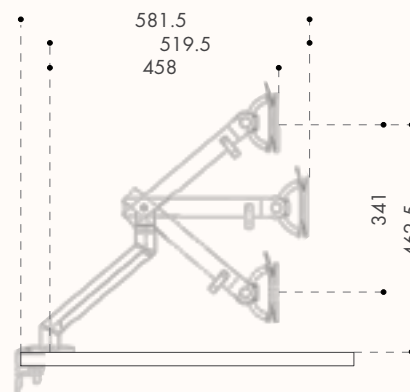

Flo Plus Monitor Arm

Features:

Flo Plus is able to support screens ranging from 6-18kg ensuring that screens with in-built processors can still be used in an ergonomic manner with a wide range of articulation. Flo Plus is able to use the patented spring technology to power the arm, ensuring minimal force/effort is required to position the screen.

Flo Plus Single

Flo Plus Single comes with a head mount to support a single screen in the load range of 8.5 - 18kg. It is compatible with a split clamp designed to fit in restricted space at rear of the desk and comes with an integrated cable management to prevent clutter of cables. The Vesa Plate attached to the arm allows users to rotate their screen portrait to landscape. It also consists of a visual indicator gauge for easy replication when installing multiple monitor arms.

Flo Plus Dual

Flo Plus Dual is designed with a Dual Mount Bar to support dual screens in the load range of 3.25kg - 8kg. It allows two widescreens of up to 24" in size to be mounted in either portrait or landscape position. The screen support heads have been designed to be reversible, enabling the user to install the screens in a 30° cockpit or flat screen setup by simply swapping the heads around on the support bar. The central swivel joint ensures installation is perfectly horizontal. Also, available with an adjustable handle for ease of movement.

Options:

- Single and dual monitor arms
- Dual Mount Bar available with Bar Handle that fits easily and securely

Design: CBS DESIGN for COLEBROOK BOSSON SAUNDERS

Warranty: 12 years

Finishes:

Flo Plus Arm, Split Arm, Dual Mount Bar Powder coat:



White

Flo Plus Single Head Mount Powder coat:



Black

Dimensions:

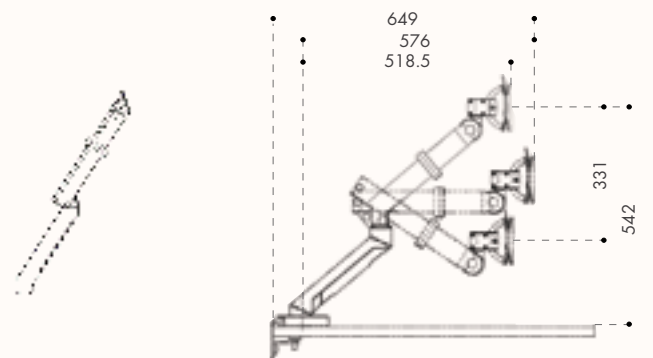

Flo Plus Single Monitor Arm

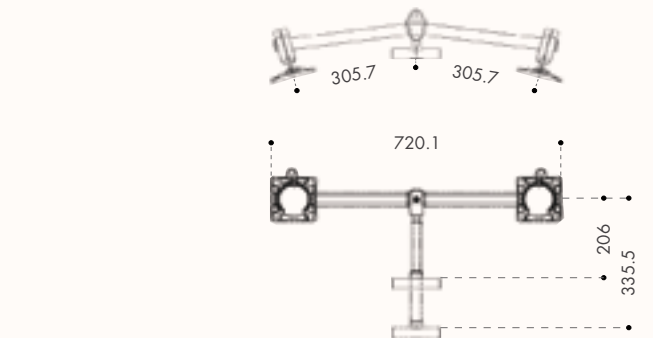
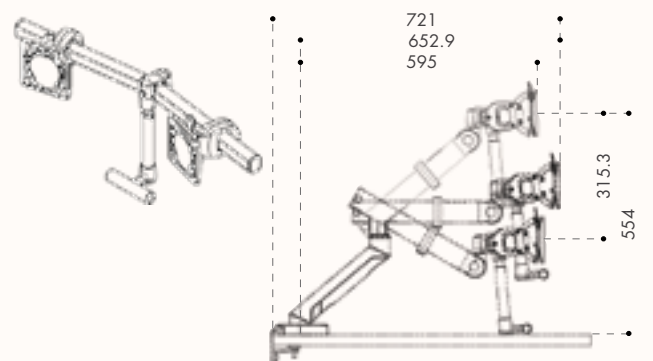

Flo Plus Dual Monitor Arm

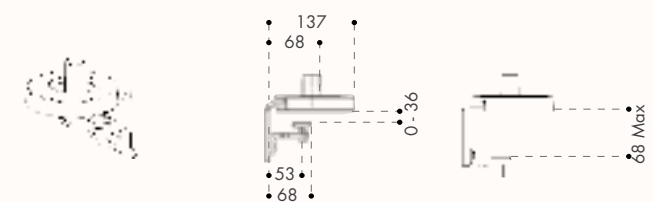

Flo Plus Split Clamp

Flo X Monitor Arm

Features:

Flo X is a new dynamic monitor arm designed to support larger and heavier displays, including widescreen and curved monitor formats. Configurable Dual Spring Technology permits support of a wide weight range - 3kg to 18kg. Available with the next generation D-Ring tilt permits enhanced support of curved monitors. Full cable management from monitor to desktop.

Design: CBS DESIGN for COLEBROOK BOSSON SAUNDERS

Warranty: 12 years

Finishes:

Powder coat:



White



Black

Dimensions:

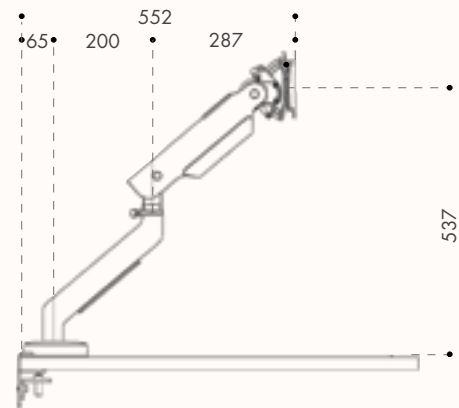

Highest Arm Position

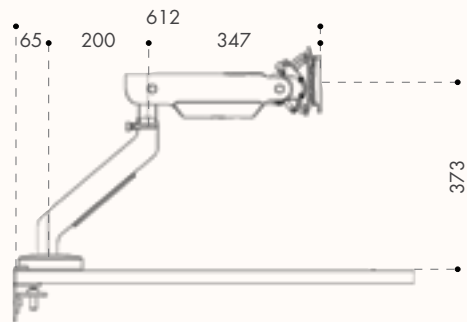

Mid Arm Position

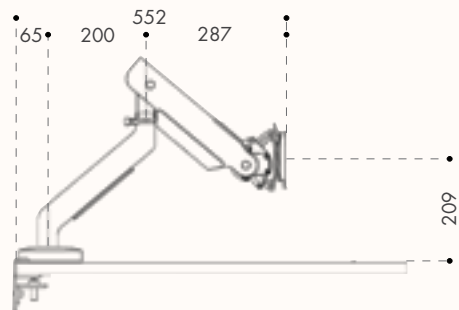

Lowest Arm Position

Lima Monitor Arm

Features:

Lima monitor arm is easy to install and adjust. It comprises of a clamp, post and require minimal tools to install. The post and clamp comes in one piece, which attaches to the desk using a thumbwheel screw, and the arm then slides into the grooves on the post. Adding another monitor is quick and easy to do. Just use another Lima arm, and slide it directly on to the post. No tools, and no need to remove the existing arm, screen and cables. With the press of a button, Lima allows you to move a screen up or down to the ideal height. And if using dual screens, users can move each one independently. Being able to tailor each screen height and distance to the users unique needs helps them to adopt a good posture and allows for healthy interaction between the users and their technology. Lima's head offers the ability to tilt the screen up to 80 degree back or 10 degree forward. This helps users to set the screen to their unique specifications, taking into consideration lighting in their workspace and the increased use of touchscreen devices in the modern workspace. Lima monitor arms also supports a monitor for up to 6.5kg and available with a 3 point cable management guide to prevent clutter of cables. Material selection and 'design-for-disassembly' make Lima 100% recyclable at the end of its operational life.

Options:

- Single or dual monitor arm

Design: CBS DESIGN for COLEBROOK BOSSON SAUNDERS

Warranty: 12 years

Finishes:

Powder coat:



White



Black

Dimensions:

LMA/001/001 Lima Arm including Post & Clamp & LMA/001/002 Lima Arm

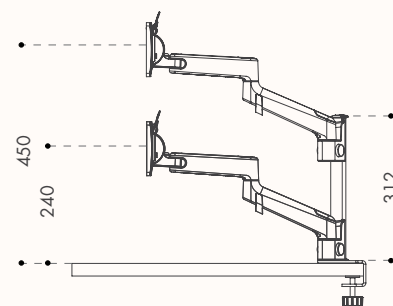

Vertical Reach

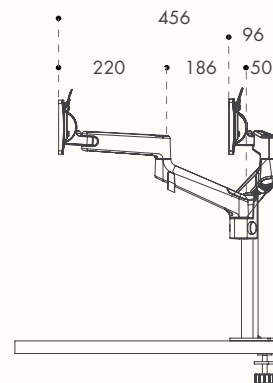

Horizontal Reach

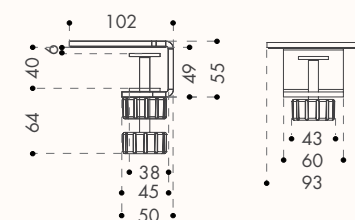

Clamp

M2.1 Monitor Arm

Features:

M2.1 Single Monitor Arm supports a better working posture, creates more usable desktop space and helps maintain a clutter-free environment. It offers quick, simple installation and industry-leading flexibility thanks to patent-pending Quick Release joints that instantly snap together for a secure and robust fit. With innovative features like its Compensator Mechanism and Self-Lubricating Precision Bearings, M2.1 allows users to effortlessly adjust their monitor to their optimal ergonomic position while also providing top-to-bottom cable management. It features the lowest cost of ownership of any monitor arm, meaning it is the easiest, quickest, and most cost-effective arm to install and modify for future moves, additions and changes to the workstation. Smart Stop allows the user to customize the rotation of the arm, preventing overhang and protecting surrounding equipment. In addition, a built-in Counterbalance Indicator provides the ability to counterbalance the monitor weight before monitor installation to reduce expensive computer setup costs. Quick Release Joints instantly snap together for a secure and robust fit, simplifying installation.

The arm is able to hold up to 2.5 - 7kg.

Options:

- M/Connect 2 docking station and M/Power integrated docking stations, to conveniently bring power and data directly to the user

Design: HUMANSCALE

Warranty: 15 years

Finishes: Monitor Arms powder coated in polished aluminium with white trim or black with black trim.

M/Connect 2 Docking Station Powder coat:



White



Black

Dimensions

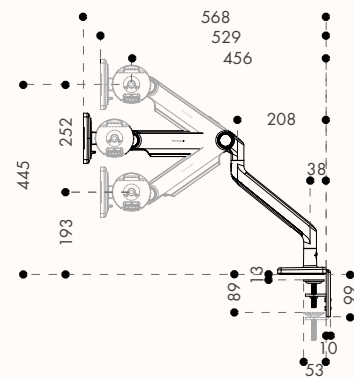

Single Monitor Arm

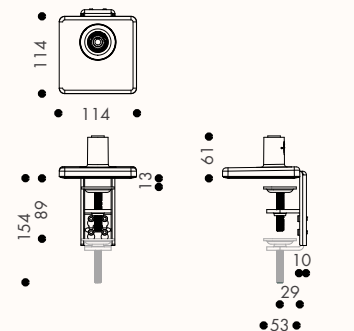

Standard Clamp & Base

M8.1 Monitor Arm

Features:

M8.1 is a monitor arm that instantly improves the comfort, health and productivity of any workspace. It is a heavy duty monitor arm that allows the user to view their 2.8 – 12.7kg monitor at an optimal ergonomic position. Available with flexible rubber channels that easily hide, protect and manage your cables. A patented, weight-compensating spring technology enables smooth and uniform height adjustment. A built-in Counterbalance Indicator provides the ability to counterbalance the monitor weight before monitor installation to reduce expensive computer setup costs. Patent-pending Smart Stop allows the user to customize the rotation of the arm, preventing overhang and protecting surrounding equipment. Patent-Pending Quick Release Joints instantly snap together for a secure and robust fit, simplifying installation. Only one tool is required, and its neatly concealed inside the arm base.

M8.1 Dual Monitor Arm comes with a crossbar support. It is available with a two piece clamp mount with base and is fully compatible with both traditional desks and sit to stand workstations.

Options:

- Single or dual monitor arm
- M/Connect 2 docking station and M/Power integrated docking stations, to conveniently bring power and data directly to the user

Design: HUMANSCALE

Warranty: 15 years

Finishes: Monitor Arms powder coated in polished aluminium with white trim or black with black trim.

M/Connect 2 Docking Station Powder coat:



White



Black

Dimensions:

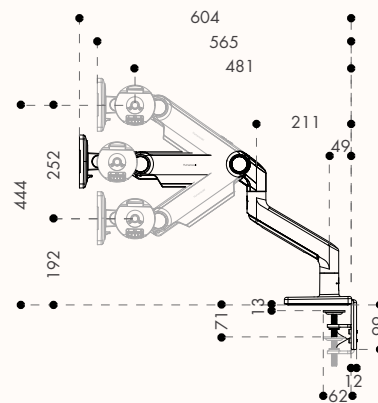

Single Monitor Arm

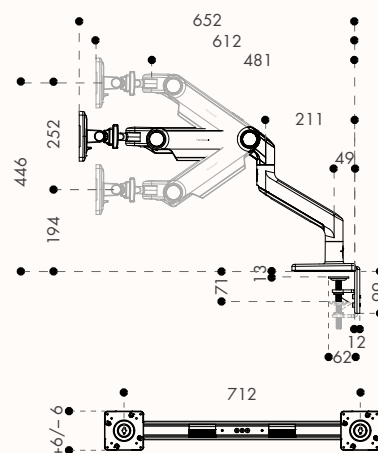

Dual Monitor Arm with Crossbar Support

Ollin Monitor Arm

Features:

Ollin is a revolutionary monitor arm that supports the screen technology of today and helps the user prepare for the screen technology of the future. It is designed with ease of adjustment to support better posture; because it's so easy to move the screen to exactly the right position.

Ollin Dynamic Monitor Arm

The Dynamic monitor arm is powered by innovative 'Technical Cord' system and is able to be reconfigured 180 degrees to prevent clashing with rear mounted furniture panels. It comes with a Vesa Tilt Head that fits quickly and easily to the Ollin Monitor Arm. Quick-release Vesa plate with optional security screw is also available. The Vesa Tilt Head allows users to rotate their screen portrait to landscape. The monitor arms support 0kg to 9kg load range, ideal for mounting lighter technology such as slim and lightweight monitors, tablets and laptops. Available with a 3 point cable management guide to prevent clutter of cables and a range of interchangeable front-end accessories to tailor the function of the arm, including: Dual Screen Mount Bar, Tablet Mount and Laptop Mount.

Ollin Dual Mount Bar

The Dual Mount Bar can be attached to the Ollin monitor arm (as a direct replacement for the standard VESA tilt head). It supports 0kg to 8kg load range and features integrated cable management. It is also designed with a central pivot to permit horizontal leveling of the complete dual bar.

Options:

- Single Dynamic Monitor Arm and Dual Mount Bar
- Dual Mount Bar available with Bar Handle the fits easily and securely

Design: CBS DESIGN for COLEBROOK BOSSON SAUNDERS

Warranty: 12 years

Awards: Reddot Design Award Winner 2017

Finishes:

Power coat:



White

Black*

Note: *Dual Mount Bar, Dual Mount Bar Handle & Vesa Tilt Head in black only.

Dimensions:

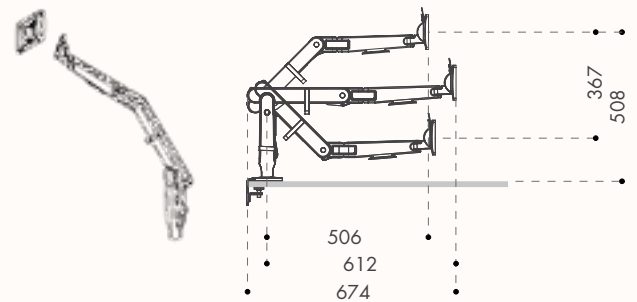

Single Dynamic Monitor Arm

Configuration shows Ollin mounted to a Split Clamp

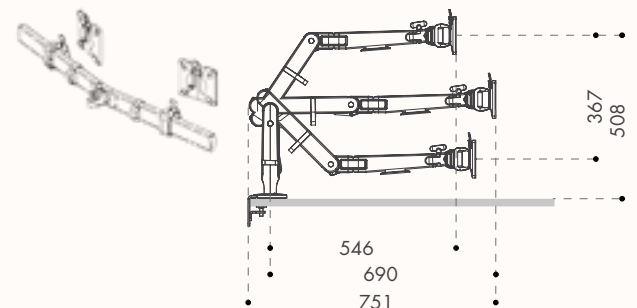

Dual Mount Bar

Configuration shows Dual Bar mounted to Ollin Arm on a Split Clamp

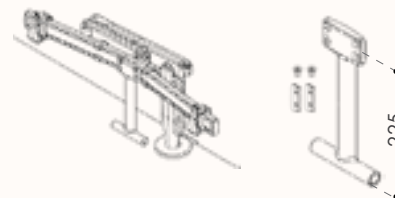

Dual Mount Bar Handle